

INTELLIREAM™ MP

SIMPLE . SMART . RELIABLE

ROBOTIC TORCH MAINTENANCE CENTER

Extend the life of your robotic MIG torch and improve cycle time in your robotic welding cell with the next generation INTELLIREAM MP. This robotic torch maintenance center systematically removes and limits spatter accumulation for enhanced productivity.

The INTELLIREAM MP is designed with reliability in mind. The internal components are modular and protected from the environment.

PROCESS HIGHLIGHTS



1) High strength coated reaming bit provides enhanced wear resistance. Precision machined to tight tolerances for optimized performance.



2) Vortex action sprayer delivers a radial spray pattern to uniformly coat the interior surface of the nozzle. Self cleaning with postflow logic.



3) Pinch off wire cutter is integrated in the clamp housing for easy and quick access, minimizing robot movement. (Optional)



4) Tapered cone provides a visual check to ensure positional accuracy of the TCP (tool center point).

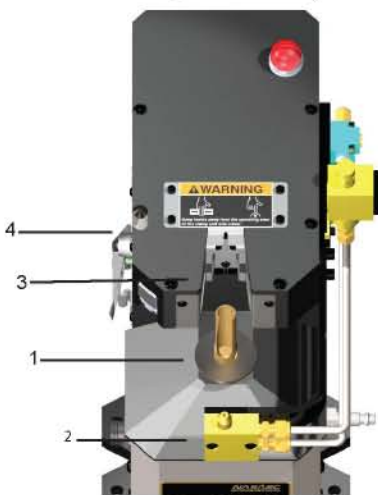

HIGHLIGHTS

- The INTELLIREAM MP controller features a simple "No Trial - No Error" programming technique and constant process monitoring.
- Self centering grip design for positive traction on all nozzle sizes.
- Complete enclosure seals out small particles and contaminants.
- On board diagnostics indicate position and fault codes for ease of troubleshooting.
- A status light signals when the unit is operating and flashes diagnostic codes if a fault occurs.
- Dry run and sensor override modes make setting up and troubleshooting easier.
- The INTELLIREAM is the only reamer to offer an automatic retry feature.

TECHNICAL DATA

Footprint Size	25"H x 13"L x 10"W
Cutter Speed	1100 RPM
Air Driven Motor	0.65 HP
Wire Cut Diameter	0.030" - 1/16"
Air Supply	80 PSI, 15 SCFM
Power Supply	24Vdc, 0.65A

United States:
Nasarc Industries, Inc.
222W. College Ave., Suite 2a
Appleton, Wisconsin 54911
Tel: (888) 844-0991 Fax: (920) 380-2399

Website: www.nasarc.com eMail: info@nasarc.com

Canada:
Nasarc Technologies, Inc.
695 McMurray Road, Unit 6
Waterloo, Ontario, Canada N2V 2B7
Tel: (519) 747-0336 Fax: (519) 886-9022

PERFORMANCE

The INTELLIREAM MP controls the entire reaming process. Every aspect of the reaming cycle is commanded, monitored and verified. The feedback signal to the robot is a true cycle complete signal indicating that the entire sequence has been executed without error.

FEATURES AND BENEFITS

- 1) Fail-safe reset push button overrides the INTELLIREAM MP commands to the cylinders and sends them back to their home position.
- 2) Indicator LEDs are visible to an operator and show the position of air cylinders. If a fault occurs, the on-board diagnostics report the error via flashing LED codes so that the problem can be resolved faster.
- 3) Unique programming technique: The setup pushbutton is used to sequence the reamer solenoids for ease of programming the correct position the very first time. Subsequent pressing of the button will raise the reaming head (without spinning the ream bit), then clamp and release the nozzle.
- 4) Auto configuration of sinking vs. sourcing inputs and outputs: No need to set DIP switches! The INTELLIREAM MP senses both the input and output type of the robot and sets its I/O immediately.
- 5) Error signal feedback to the robot: If an error occurs in the process, the INTELLIREAM MP returns to its home position and sends an error signal to the robot.
- 6) The electronics are enclosed in the RCM-1 CONTROL MODULE. The control module is easily removed from the side of the machine and disconnected without removing the front or rear panels.
- 7) Magnetic sensors are utilized for optimum position accuracy and reliability.
- 8) Hinged back door/panel for ease of access.
- 9) Gripper guard helps keep area clear of spatter.
- 10) Nozzle detect ensures that the nozzle is on the torch thus eliminating "bad" welds because of contamination.

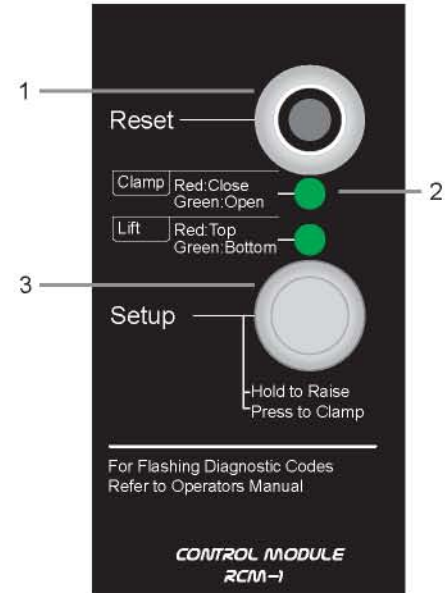

STANDARD EQUIPMENT

INTELLIREAM MP	IRM020001-MP
Nozzle Reamer	
Spray System	
TCP check	

Request any of the following options when ordering:

Wire cutter Module	IRW010099-02
Nozzle Detect.	IRE020099-02

ACCESSORIES

Reaming Bit, 1/2"	IRB010500-00
Reaming Bit, 1/2" Bottleneck	IRB010501-00
Reaming Bit, 15.5mm	IRB01M155-00
Reaming Bit, 5/8"	IRB010625-00
Reaming Bit, 3/4"	IRB010750-00
Robot control cable, 20ft	IRB010090-20
Robot control cable, 30ft	IRB010090-30
Robot control cable, 50ft	IRB010090-50
Test Box	IRT010001-00
Spatter Tray, bracket & Cone	IRF010099-01
Adaptor Plate	IRF020002-01
Floor Mount Stand	IRX010001-00

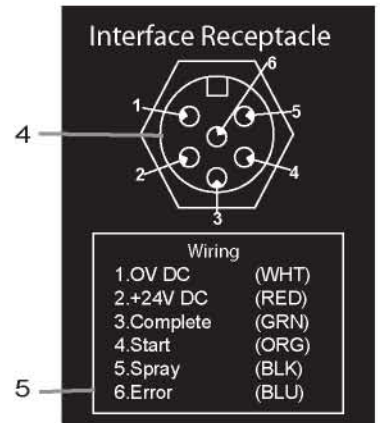

For more information, contact your local Nasarc distributor.