

INTELLIREAM[®] DD-IOL

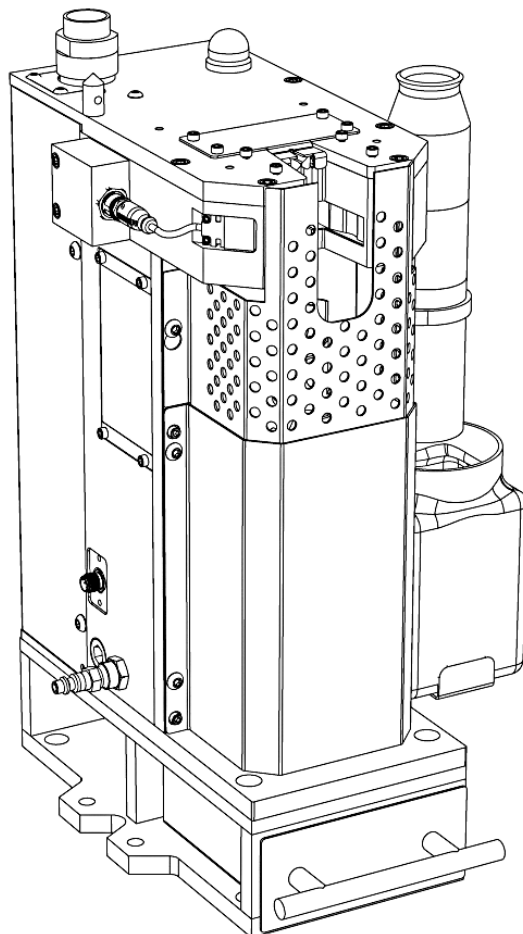

Safety Depends on You

DO NOT INSTALL, OPERATE, OR REPAIR THIS EQUIPMENT WITHOUT READING THIS MANUAL AND THE SAFETY PRECAUTIONS CONTAINED THROUGHOUT.

OWNER'S MANUAL

Effective with serial No. IR2507004 & following.

"U.S. Patent No.: 7,952,052"

Nasarc Technologies, Inc.
602 Colby Drive
Waterloo, Ontario, N2V 1A2
Tel: (519) 747-0336, Fax: (519) 886-9022
WWW.NASARC.COM

Safety Information

Before installation and commissioning of the INTELLIREAM® DD-IOL, please read and understand all of the following safety information. Failure to follow these instructions may result in damage to the equipment or personal injury.

The INTELLIREAM® DD-IOL is constructed to be safe to operate provided:

- Only authorized personnel may perform installation, commissioning, and maintenance in observance of all safety precautions contained in these operating instructions.
- Accident prevention regulations, as well as the safety specifications referenced below are observed.
- ANSI/RIA R15.06-2012 Industrial Robots and Robot Systems – Safety Requirements

For additional safety information see references below:

This product shall be integrated into a robot cell with an independent safety system.

Before assembling, adjusting, or working with the INTELLIREAM® DD-IOL, ensure all equipment in the area is disabled.

The INTELLIREAM® DD-IOL is to be used only for torch cleaning within the technical operating specifications outlined in this document.

Do not exceed the specified operating pressure of 80 PSI.

Keep hands away from INTELLIREAM® DD-IOL while in operation.

Keep hands away from the clamp and INTELLIREAM® DD-IOL operating space.

Keep hands away from the wire cutter.

Keep eyes away from the sprayer.

Protective eyewear should be worn at all times while working in the vicinity of the INTELLIREAM® DD-IOL.

Protective gloves should be worn at all times when maintaining the INTELLIREAM® DD-IOL.

Disconnect the air and power supplies when adjusting the INTELLIREAM® DD-IOL.
Use only OEM parts and accessories.

Do not use corrosive or aggressive chemicals without first obtaining approval from the manufacturer.

Do not remove or deface warning and instruction labels on the INTELLIREAM® DD-IOL.

For additional safety information, refer to the following publications:

- ANSI/RIA R15.06-2012 Industrial Robots and Robot Systems – Safety Requirements
Robotic Industries Association, 900 Victors Way, Suite 140, Ann Arbor, Michigan, USA 48108
- ANSI Z49.1:2012 Safety in Welding, Cutting, and Allied Processes,
American Welding Society, 550 N.W. LeJeune Road, Miami, FL 33126
- CAN/CSA-Z434-14 Industrial robots and robot systems,
Canadian Standards Association, 5060 Spectrum Way, Mississauga, Ontario, L4W 5N6, CANADA

Safety Information

⚠️ WARNING Moving parts can crush and cut. Keep hands away from the operating area of the reaming bit, clamp, and wire cutter.	
	⚠️ WARNING Rotating Cutter. Keep hands away from the operating area of the cutter.
	⚠️ WARNING Entanglement Hazard. Do not operate with exposed long hair, jewelry, or loose clothing.
	⚠️ WARNING Disconnect power before servicing.
	⚠️ WARNING Disconnect air supply before servicing.
	⚠️ WARNING Do not use damaged, frayed, or deteriorated air hoses and fittings.
	⚠️ WARNING Maintain safe operating pressure (80 psi).

Table of Contents

1. Specifications	7
2. Installation	8
2.1. Baseplate Dimensions.....	9
2.2. Air Connection	9
2.3. Electrical Connection	10
3. Operation	11
3.1. User Interface	11
3.2. Power-Up	11
3.3. Manual Operation.....	12
3.4. IO-Link Specification and Data Map	13
4. Reamer	15
4.1. Automatic Operation	15
4.2. Status Light	16
4.3. Position Programming	16
4.4. Reaming Bit Replacement.....	17
5. Sprayer.....	18
5.1. Spray Position Programming.....	18
5.2. Spray Adjustment.....	18
5.3. Spray Nozzle Replacement.....	19
5.3.1. Spray Cone Assembly with O-Rings.....	19
5.3.2. Spray Cone Assembly with Plunger	19
6. Ream and Spray Sequence Flow Chart.....	20
7. Wire Cutter Option.....	21
7.1. Wire Cutter Position Programming	21
7.2. Wire Cutter Sequence Flow Chart.....	22
8. Nozzle Detect Sensor Option	23
8.1. Nozzle Detect Position Programming	23
8.1. Nozzle Detect Sequence Flow Chart.....	24
9. Nozzle Gas Flow Sensor (NGFS) Option.....	25
9.1. NGFS Specifications	25
9.2. NGFS Setup.....	25
9.3. NGFS Robot Position and Sequence Flow Chart	26

10. Settings	27
10.1. Running Mode.....	27
10.2. Motor Test.....	28
11. Preventive Maintenance	30
12. Troubleshooting.....	31
12.1. Error Codes.....	32
13. Pneumatic Components	33
14. Electrical Diagram	34
15. Replacement Parts List	35
Warranty.....	39

Manual Revision History

Revision	Description	Date	Editor
1.1	Initial Release	March-2023	J. Rice, M. Tremblay
1.2	Cobot has been removed	October-2025	C. Vaghela, M. Tremblay
1.3	Spray cone O-ring assembly added (ECN 2601-04)	February- 2026	C. Vaghela, M. Tremblay

INTELLIREAM® DD-IOL

1. Specifications

PNEUMATIC SPECIFICATIONS	
Pressure: 80 PSI	Flow: 18 SCFM
Caution: Use Filtered (5um), Non-Lubricated, Regulated Air	

ELECTRICAL SPECIFICATIONS	
Voltage: 24 VDC +/- 10%	Current: 0.3 Amp* DC

REAMING SPECIFICATIONS	
Speed: 320 RPM	Power: 0.50 HP

WIRE CUTTING SPECIFICATIONS
Minimum wire diameter: 0.030" (0.8mm)
Maximum wire diameter: 0.063" (1.6mm)

ANTI SPATTER FLUID SPECIFICATIONS
Use recommended water based anti-spatter fluid in this product.
Do not use oil based anti-spatter fluid.

PHYSICAL DIMENSIONS			
HEIGHT	WIDTH	DEPTH	NET WEIGHT
19 in.	10.5 in.	12 in.	44 lbs
483 mm	267 mm	305 mm	20 kg

*Ensure the IO-Link Hub used is capable of supplying at least 0.3A per each device port. Contact Nasarc sales for optional power supply configurations.

INTELLIREAM® DD-IOL

2. Installation

Danger of accident when connecting the pneumatic or electrical supply!

- Prior to installation ensure that all protective measures have been taken and will remain in place while performing the installation.
- Ensure that the air supply and electrical power to the INTELLIREAM® DD-IOL are disconnected until the installation is complete.
- The INTELLIREAM® DD-IOL should be installed within the weld cell at a convenient location. Be sure to consider movable fixtures, robot envelope, and maintenance personnel accessibility.

When using the mounting box with spatter discharge tray (optional):

- Affix the mounting box to a sturdy platform using the four bolt holes with provided mounting hardware.
- Affix INTELLIREAM® DD-IOL to the mounting box platform using mounting hardware provided.

When not using the mounting box:

- Note: spatter discharge may be managed more effectively if allowed to pass through the hole in the base plate to a customer supplied catchment device (see diagram below).
- Affix the INTELLIREAM® DD-IOL to a sturdy platform using the four bolt holes provided for 3/8" mounting hardware.

Before operating the INTELLIREAM® DD-IOL, ensure that the correct reaming bit for the torch nozzle is installed.

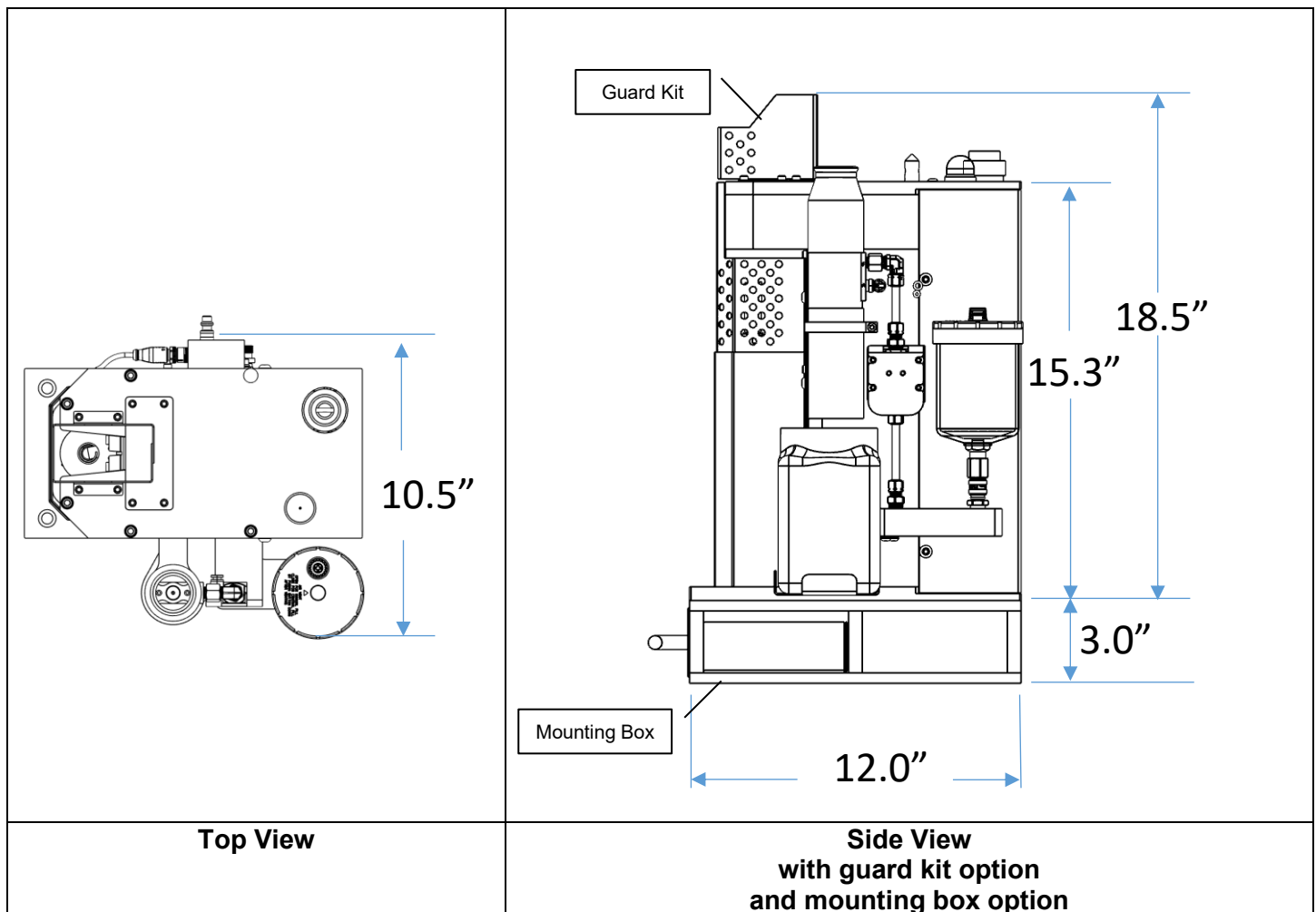

INTELLIREAM® DD-IOL

2.1. Baseplate Dimensions

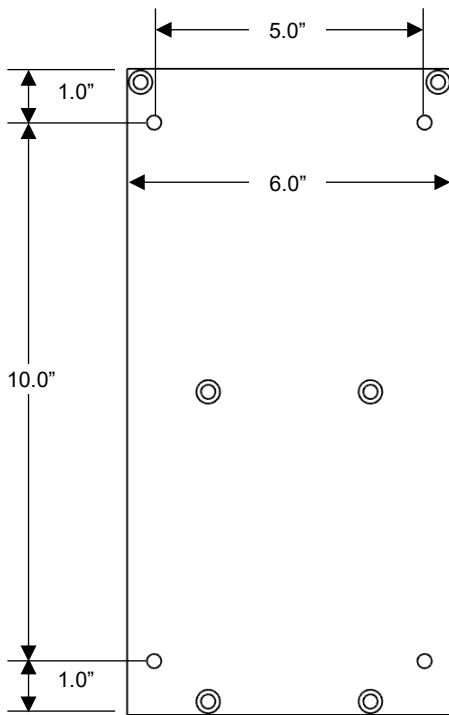

Mounting Box Bottom View

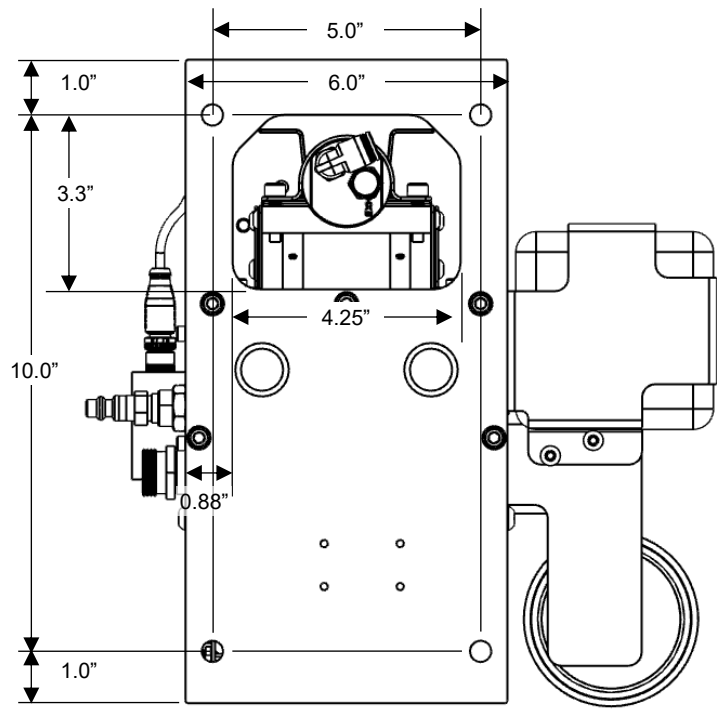

Reamer Base Bottom View

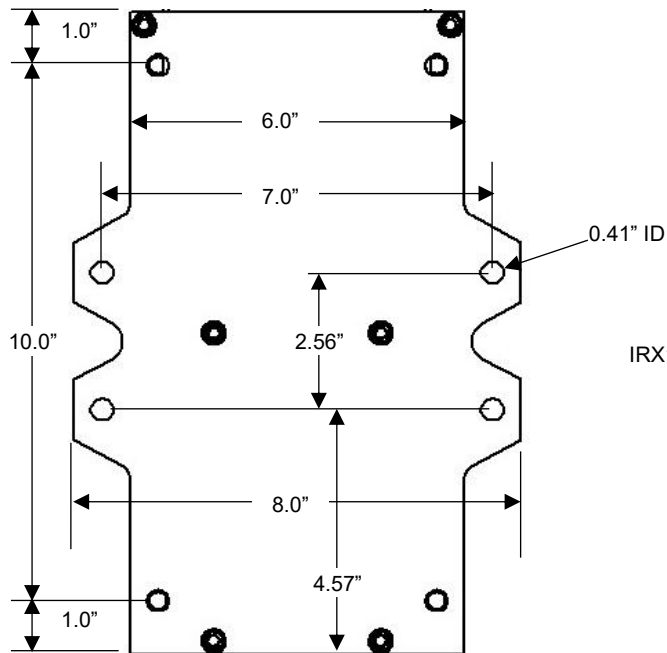

IRX120099-02 Wing Box Bottom View

2.2. Air Connection

Use only regulated, filtered, non-lubricated air. Mount a 5-micron airline filter (not supplied) in the airline to the INTELLIREAM® DD-IOL.

AIR SUPPLY REQUIREMENTS: 80 PSI at 18 SCFM. Connect the inlet supply line to the quick connect pneumatic fitting located at the side of the INTELLIREAM® DD-IOL.

2.3. Electrical Connection

WARNING: Damage to equipment may occur if connected improperly. Only a qualified technician should perform the following operation: Secure the connector into the receptacle at the side of the INTELLIREAM® DD-IOL, then connect the opposite side to a port on an IO-Link master.

Class A type wiring

Color	Name	Description
Brown	+24VDC Control	Connect to power supply (+) 24VDC, 0.3A minimum
White	Input	*Motion enable input
Blue	0VDC Control	Connect to power supply (-) 0VDC, 0.3A minimum
Black	C/Q	IO-Link Serial Communications

**IO-Link
Interface Wiring**

1. +24 VDC Control	(BRN)
2. Input / Motion Enable	(WHT)
3. 0 VDC Control	(BLU)
4. C/Q IO-Link	(BLK)

 **IO-Link**

*The motion enable input must be active (+24Vdc) for the clamp, wire cut, lift, and ream motor to operate in automatic or manual operation. The motion enable input may be jumpered out (see Electrical Diagram section 14).

3. Operation

3.1. User Interface

The user interface is part of the Reamer Control Module (RCM-IOL) and can be found on the electrical supply side of the INTELLIREAM® DD-IOL (opposite the reservoir). The user interface provides the following features:

- Manual operation of the clamp, lift and spray system.
- The status of each solenoid is shown on its respective button.
- Monitor sensor operation of the clamp and lift reed switches.
- Input / Output configuration and other feature settings.
- Control logic reset.

Item	Name	Description
1	Settings	Settings mode and status
2	Reset	Device and control logic reset
3	CLAMP	Solenoid activation and status
4	CLAMP Sensor	Status (Red / Green)
5	LIFT	Solenoid activation and status
6	LIFT Sensor	Status (Red / Amber / Green)
7	SPRAY	Solenoid activation and status

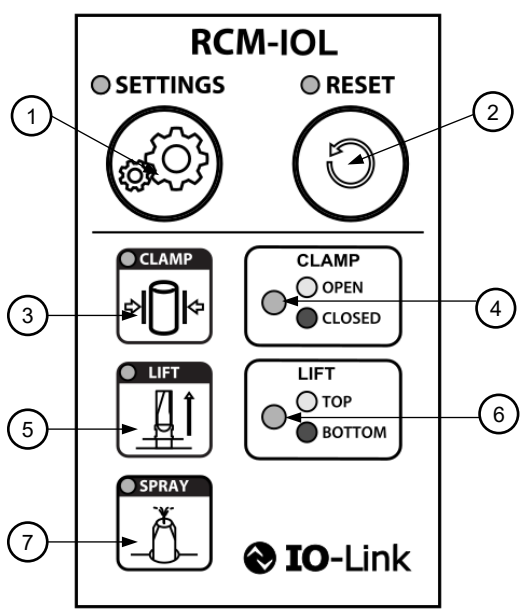

The diagram shows the RCM-IOL control panel with the following components labeled with callouts:

- 1: Settings button (gear icon)
- 2: Reset button (circular arrow icon)
- 3: CLAMP solenoid activation button (cylinder icon)
- 4: CLAMP sensor status indicator (OPEN/CLOSED)
- 5: LIFT solenoid activation button (cylinder with arrow icon)
- 6: LIFT sensor status indicator (TOP/BOTTOM)
- 7: SPRAY solenoid activation button (spray nozzle icon)

The IO-Link logo is also present at the bottom right of the panel.

3.2. Power-Up

Once the INTELLIREAM® DD-IOL is wired into the controller and power is applied, the device status LEDs will display the power up sequence (green – yellow – red) and then show positions of the cylinders according to the legend next to the LEDs.

Power Up LED check	→				
CLAMP ● OPEN (Green) ● CLOSED (Red)	G	Y	R	○	G
LIFT ● TOP (Red) ● BOTTOM (Green)	G	Y	R	○	G

If the sensor LEDs are not reporting the clamp open and the lift at the bottom, then check the air pressure or sensor positions. If the sensor LEDs are flashing yellow and green, check for **start lock** (see below). If the LEDs are flashing yellow, ensure the settings pushbutton is not pressed or defective.

INTELLIREAM® DD-IOL

Start Lock: The start lock feature is a safety measure that blocks a command signal during power-up when it is unsafe to begin an operation. If a command is present while the INTELLIREAM® DD-IOL powers up or after an error reset, the INTELLIREAM® DD-IOL will enter a start lock mode instead of cycling immediately and the “Error” input will turn on. During power up, the device status LEDs will display the power up sequence (green-yellow-red) and then flash yellow/green if an output from the controller is present. To resume operation, turn off all controller outputs to the INTELLIREAM® DD-IOL.





Ready: (robot input) If the device has completed the power up sequence, and is not in cycle, the “Ready” input will turn on when **ALL** of the following conditions are met:

- All command signals (robot outputs) are off: Ream, Spray, Wire Cut.
- Remote mode is off; all remote mode signals are all off.
- Local lockout mode is off (manual operation or membrane activity).
- Motion enable is active (or jumpered out).
- Solenoid voltage >20V is present.
- Clamp is open.
- Lift is retracted.

Error: (robot input) If a fault has occurred during a machine operation, the “Error” input will be on. See trouble shooting section for error codes.

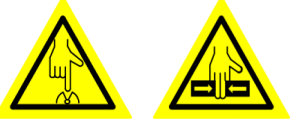
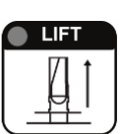
3.3. Manual Operation

Operation of the clamp, lift and spray valves is possible with the buttons on the user interface. The green LED indicator at the top left shows button feedback and solenoid operation. The sensor LED indicators to the right indicate the sensor feedback of the corresponding device. If the motion enable signal is off during manual operation of the clamp or lift, the corresponding LED will flash quickly.

	 <p>WARNING: the clamp will operate in this condition. KEEP HANDS CLEAR of the operating space of the clamp and wire cutter. This device is intended for one-man operation during setup.</p>
	 <p>WARNING: the lift cylinder will operate in this condition. KEEP HANDS CLEAR of the operating space of the reaming bit. This device is intended for one-man operation during setup.</p>
	 <p>WARNING: the spray will operate in this condition. KEEP FACE and HANDS CLEAR of the operating space of the sprayer. This device is intended for one-man operation during setup.</p>

Note: a “Local Lockout” mode is enabled for 3 seconds following the press of any of these buttons. Robot I/O is disabled and the LEDs blink slowly during this time.

INTELLIREAM® DD-IOL

3.4. IO-Link Specification and Data Map

The INTELLIREAM® DD-IOL must be connected to an IO-Link master for full functionality.

IO-Link Specifications

Data transmission rate	COM2 (38.4 kBaud)	
Minimal cycle time	10ms	
IO-Link Version	1.1	
IO-Link port type	Class A	
Vendor ID	1842	
Device ID	101	
Process Data In Length	32 bits	
Process Data Out Length	16 bits	
SIO mode	No	
Smart Sensor Profile	No	
Block parameterization	No	
Data Storage	No	

IO-Link Process Data Out (Master to Device)

Address	Name	# Bits	Data Values	Notes
[0].0	Ream	1	0 - 1	Start ream cycle.
[0].1	Spray	1	0 - 1	Start spray cycle.
[0].2	Wire Cut	1	0 - 1	Start wire cut cycle.
[0].3	Reset Error	1	0 - 1	Reset error bit and error code. !! Turn off all outputs before resetting the error.
[0].4	Reset PM Count	1	0 - 1	Reset PM (preventive maintenance) cycle count to zero, also resets "call for PM" status.
[0].7	De-ring Enable	1	0 - 1	Enable an initial half stroke to remove the spatter ring prior to full depth reaming.
[1].0	Remote Mode	1	0 - 1	Set this bit to enable the following commands. [1].1 through [1].6
[1].1	Clamp Solenoid	1	0 - 1	Activate the clamp solenoid.
[1].2	Lift Solenoid	1	0 - 1	Activate the lift solenoid.
[1].3	Motor Solenoid	1	0 - 1	Activate the motor solenoid.
[1].4	Air Spray Solenoid	1	0 - 1	Activate the pressurized air solenoid on the spray system.
[1].5	Fluid Solenoid	1	0 - 1	Activate the fluid solenoid.
[1].6	Status LED	1	0 - 1	Flash the status light at a fast rate.

INTELLIREAM® DD-IOL

IO-Link Process Data In (Device to Master)

Address	Name	# Bits	Values	Notes
[0].0	Ready	1	0 - 1	Clamp is open, lift is retracted, motion enable is active, solenoid power is available unit is not in remote mode, local lockout or start lock.
[0].1	Error	1	0 - 1	A cycle error has occurred, see Error Code below and section 12.1 for description.
[0].2	Solenoid Power	1	0 - 1	+24V power is available for solenoids and motion enable is active.
[0].3	Clamp Open	1	0 - 1	Status of nozzle clamp.
[0].4	Lift Retracted	1	0 - 1	Status of ream motor lifting system.
[0].5	Lift Extended	1	0 - 1	Status of ream motor lifting system.
[0].6	Nozzle Detect	1	0 - 1	Status of Nozzle Detect option.
[0].7	Gas Flow Detected	1	0 - 1	Gas flow exceeds 30% sensor range.
[1].0	Local Lockout Active	1	0 - 1	See section 3.3.
[1].1	Call for Repair	1	0 - 1	An error has occurred. Reset with power cycle.
[1].2	Call for PM	1	0 - 1	Current PM count exceeds setpoint.
[2]	Error Code	8	0 - 9	See section 12.1.
[3]	Gas Flow Sensor	8	0 - 100	Real time flow reading as a percentage of the sensor range.

Parameters Set Using IO-Link

Index	Sub-Index	Parameter Array Address	Read / Write	Name	# Bits	Data Values	Note
1	1	[0]	rw	PM Count Setpoint x 100	8	0-255	Set this variable > 0 to enable "Call for PM".
	2	[1]	rw	Max Retries Allowed	8	0-3	Retry limit (see section 4.1).
	3	[2]	rw	Post Flow Index	8	0-3	Post flow index (see section 5).
	8	[7]	ro	Current PM Count x 100	8	0-255	Cycle count for comparison to PM count setpoint.
	9,10	[8]msb [9]lsb	ro	Cycle Count x 1000	16	0-65535	Lifetime cycle count.

4. Reamer

4.1. Automatic Operation

The following diagram shows the 7-step reaming sequence and color of the device status LEDs at each stage. The LEDs show the position of the clamp and lift cylinders on the control module.

		1	2	3	4	5	6	7
CLAMP ● OPEN ● CLOSED		G	R	R	R	R	R	G
		G	G	Y	R	Y	G	G
LIFT ● TOP ● BOTTOM		Ready	Clamp Closed	Raising Ream Bit	Ream Bit at Top	Lowering Ream Bit	Ream Bit at Bottom	Clamp Open
"Start" Output	→		Pulse 0.5s	Off				
"Complete" Input	On	On	Off					On

The above chart shows the robot inputs and outputs as the sequence progresses.

Automatic Retry

If excessive spatter is built up in the nozzle, or the programmed position of the nozzle is off center not allowing the reaming bit to extend to the full depth inside the nozzle within a specific amount of time. The number of automatic retries must be set using IO-Link parameters (see section 3.4).

Cycle Optimization

The lift rate of the reaming bit will determine how many reaming revolutions will occur within the nozzle. This setting should be adjusted based on the amount of spatter buildup in the nozzle between reaming cycles. More spatter buildup will require a slower lift rate. Less spatter buildup will allow a faster lift rate.

To set the lift rate, remove the rear cover and adjust the top needle valve. Turning clockwise will decrease the lift rate (for more spatter removal) and turning counterclockwise will increase the lift rate (for a shorter cycle time).

To set the retracting rate, adjust the bottom needle valve. Turning clockwise will decrease the retracting rate and turning counterclockwise will increase the retracting rate.

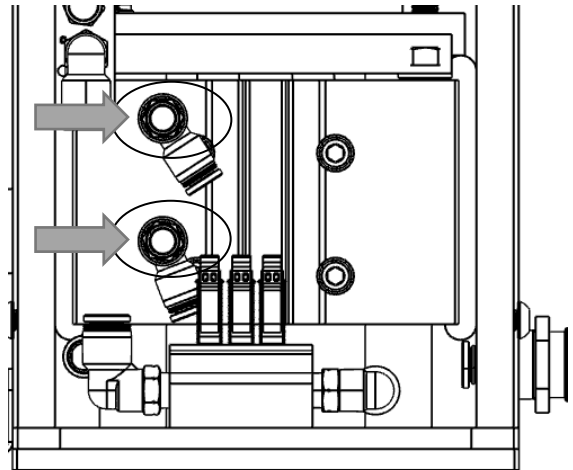

INTELLIREAM® DD-IOL

4.2. Status Light

The status light on the top lid of the INTELLIREAM® DD-IOL indicates the current state of operation.

Color	Meaning
Off	Ready to cycle
Red	In cycle or manual operation
Blinking 0-9 times	In alarm, flashing error code
Blinking quickly	“Find Me” selected in remote mode.

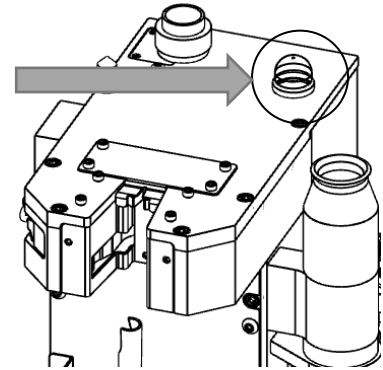

4.3. Position Programming

The INTELLIREAM® DD-IOL features a “no trial, no error” position programming technique as described below:

1. Hold the “LIFT” button to raise the reaming bit without spinning.



WARNING: the lift cylinder will operate under this condition. KEEP HANDS CLEAR of the operating space of the reaming bit. This device is intended for one-man operation during setup.

Once the reaming bit is at the top position (“LIFT” LED is red), release the “Settings” button.

2. Using the robot, move the torch nozzle into the clamp so the reaming bit is inset to the full depth required inside the nozzle.
3. Press and release the “CLAMP” button to verify the clamp engages the cylindrical body of the nozzle equally, and the nozzle does not change orientation or position when clamped.



WARNING: the clamp will operate under this condition. KEEP HANDS CLEAR of the operating space of the clamp and wire cutter. This device is intended for one-man operation during setup.

4. Register this position in the robot controller using a fine position level as the “Ream” position described in the programming chart above.

Ream Position

5. Press the “LIFT” button to exit programming mode. The reaming bit will lower without spinning.



WARNING: the lift and clamp will operate under this condition. KEEP HANDS CLEAR of the operating space of the reaming bit.

This device is intended for one-man operation during setup.

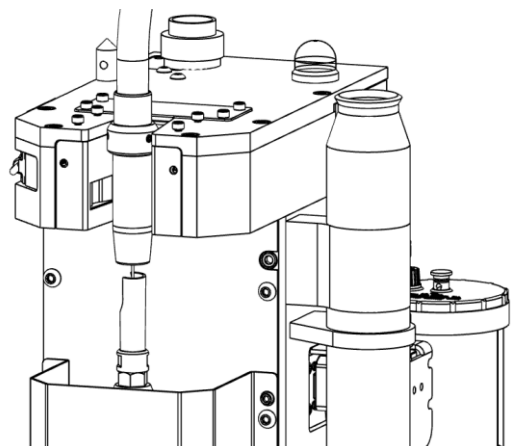

4.4. Reaming Bit Replacement

⚠ WARNING

- Disconnect air and electrical supply.
- Remove the front ream guard cover (not shown).
- Hold the ream rod, item 2, from rotating with a 5/8" wrench.
- Unfasten the reaming bit, item 1, with a second 5/8" wrench.
- Remove the reaming bit.
- Insert the reaming bit into the ream rod.
- Hold the reaming rod from rotating with a 5/8" wrench.
- Tighten the reaming bit with a second 5/8" wrench.
- Replace the front ream guard cover.
- Reconnect air and electrical supply.

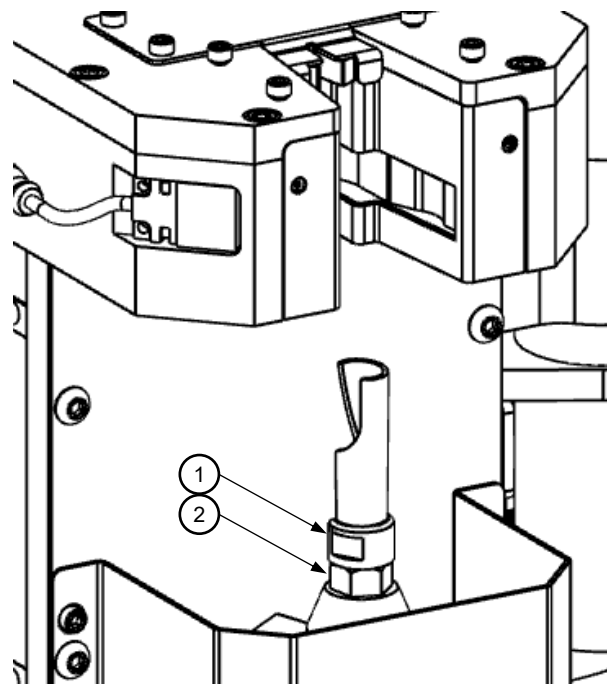

5. Sprayer

The sprayer may use a built-in post flow timer of 0, ¼, ½, or 1 second. Airflow from the spray nozzle will be present for the post flow time after the spray output and corresponding fluid valve have been turned off.

The spray containment tube helps to manage overspray from the spray nozzle and maintain a clean robot welding cell.

5.1. Spray Position Programming

Center the nozzle 1½ inches above the spray head. Record this position as the “Spray Approach” position. Move the nozzle into the hole at the top of the spray cone and record this position as the “Spray Target” position. The sprayer has a built-in post flow timer. Airflow from the spray nozzle will be present for set time (0, ¼, ½ or 1 second) after the spray output and corresponding fluid valve have been turned off.

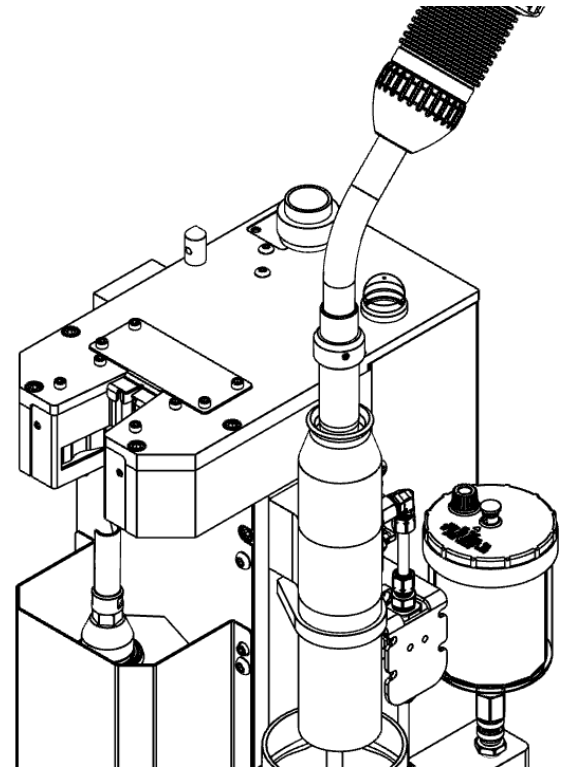

5.2. Spray Adjustment

The amount of spray may be adjusted with the needle valve, item 1, located behind the rear cover. Turn clockwise for less spray.

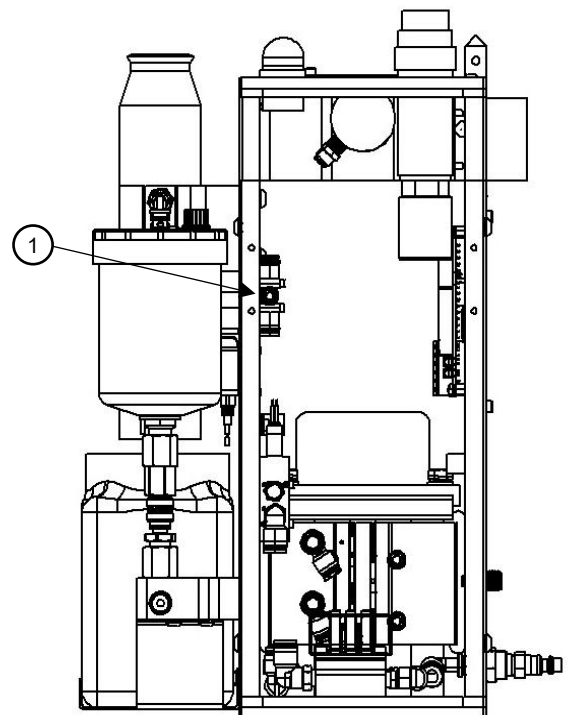

INTELLIREAM® DD-IOL

5.3. Spray Nozzle Replacement

5.3.1. Spray Cone Assembly with O-Rings

⚠️WARNING

- Disconnect air and electrical supply.
- Lift spray cone straight up to remove.
- Unfasten the two 8-32 screws using a 9/64 hex key and remove the spray manifold base.
- Unthread spray nozzle and lift straight up to remove.
- Replace in reverse order.

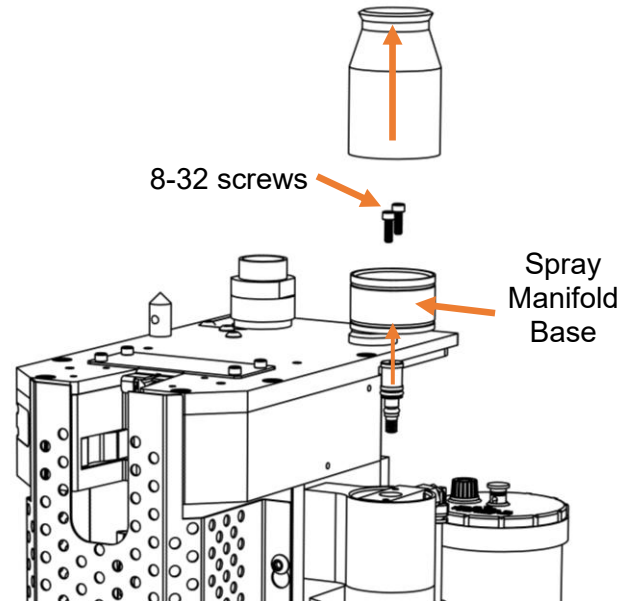

5.3.2. Spray Cone Assembly with Plunger

⚠️WARNING

- Disconnect air and electrical supply.
- Lift spray cone straight up to remove.
- Unthread spray nozzle and lift straight up to remove.
- Replace in reverse order.

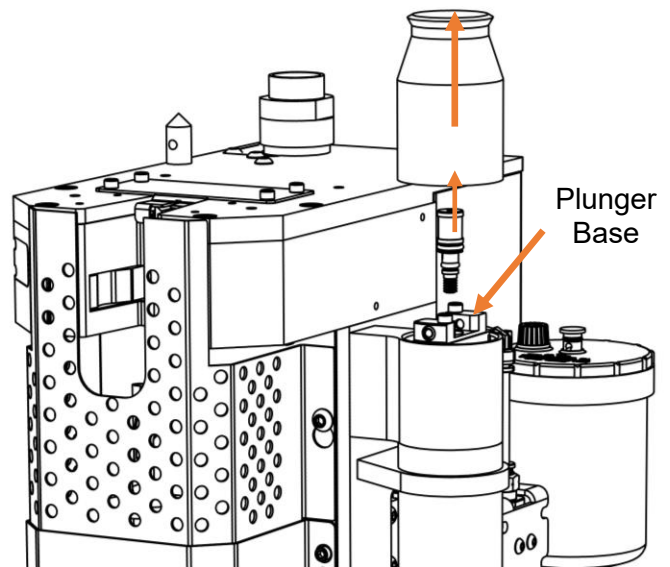

NOTE: The spray cone O-ring assembly shall be interchangeable with the spray cone plunger assemblies used on previously manufactured machines, with no modification required. The spray cone with the plunger assembly will remain available in inventory for customers who wish to continue using it. Follow section 15 Replacement Parts List for the part number and the description. Contact NASARC TECHNOLOGIES, INC., if you have any questions or concerns.

6. Ream and Spray Sequence Flow Chart

The following flow diagram shows the recommended procedure for the reaming and spraying sequences.

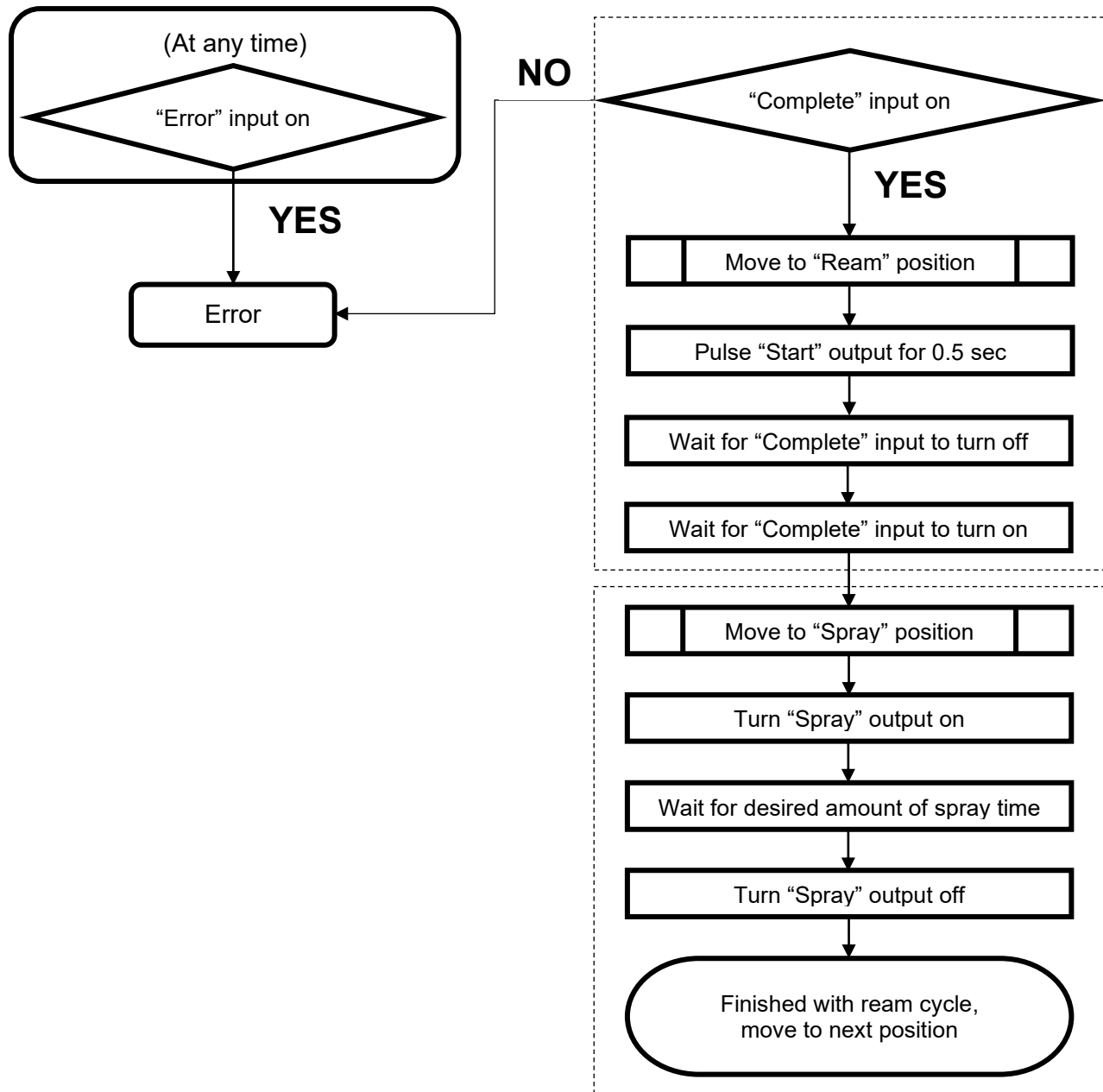

For the optional wire cutter, nozzle detector, and nozzle gas flow sensor see the following sections.

7. Wire Cutter Option

The INTELLIREAM® DD-IOL offers a wire cutter as a factory installed option (IRW010099-00). The wire cutter is used to remove the ball at the end of the wire created by the welding process. It will leave the welding wire with a tapered point at the end of the wire stick-out for improved arc starting.

7.1. Wire Cutter Position Programming

To obtain the “Wire Cut” position mentioned in the procedure outlined, center the nozzle at the desired stick-out height above the wire cutter and record this position.

Once a week, the wire cutter should be inspected visually. Look for dullness and possible breakage of the cutting blades, replace if necessary.



WARNING: Anytime the clamp is closed, the wire cutters will be closed as well. Keep hands clear of the wire cutter area and clamp area.

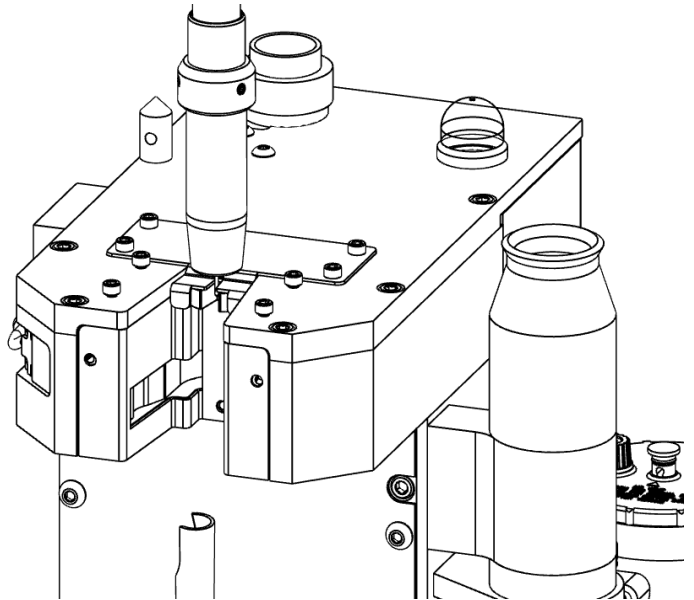

7.2. Wire Cutter Sequence Flow Chart

The wire cutter utilizes the clamping cylinder and sensor already present on every INTELLIREAM® DD-IOL. Following is the suggested wire cutting program logic.

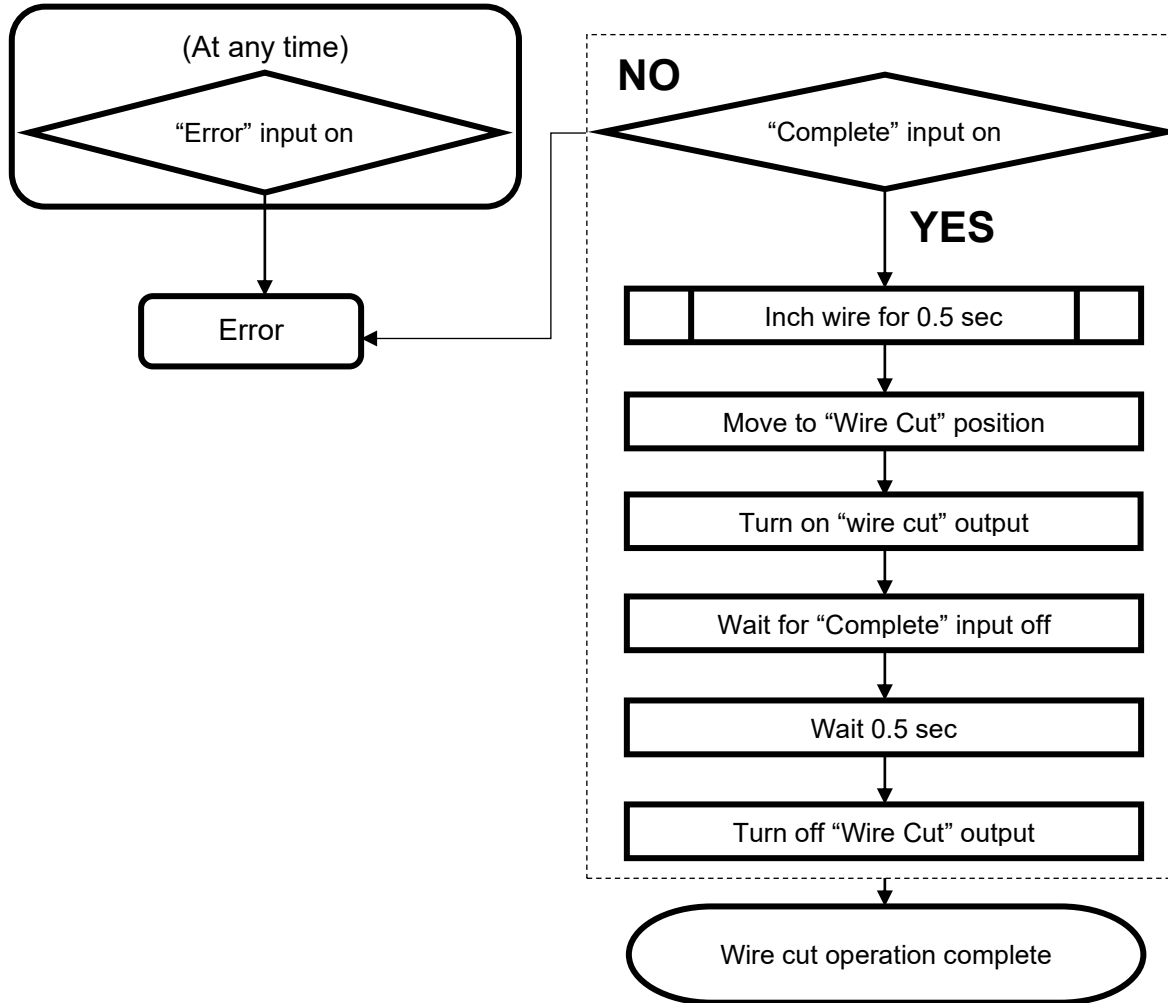

8. Nozzle Detect Sensor Option

The INTELLIREAM® DD-IOL offers a nozzle detect sensor as a factory installed option (IRE120099-02). The integrated nozzle detect sensor is used to validate that the nozzle remains on the torch after the reaming process is complete.

8.1. Nozzle Detect Position Programming

The figure below illustrates the proper nozzle detect position, where the distance between the nozzle wall and the sensor must be less than or equal to 1.5 mm.

The inductive sensor has a maximum sensing range of 1.5 mm

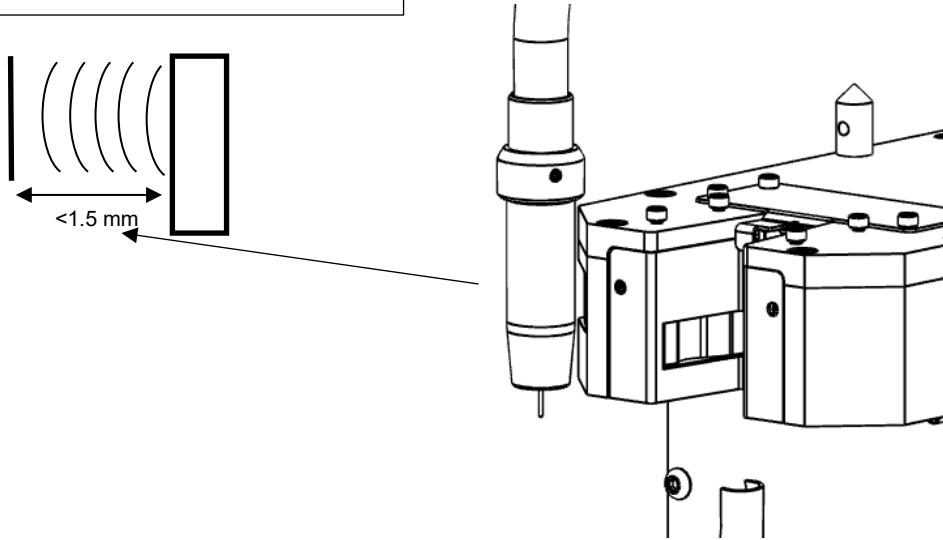

When a nozzle is detected by the sensor, the “Nozzle Detect” input will turn on and the “Ready” signal will turn off.

8.1. Nozzle Detect Sequence Flow Chart

The process for checking for nozzle presence is outlined in the diagram below.

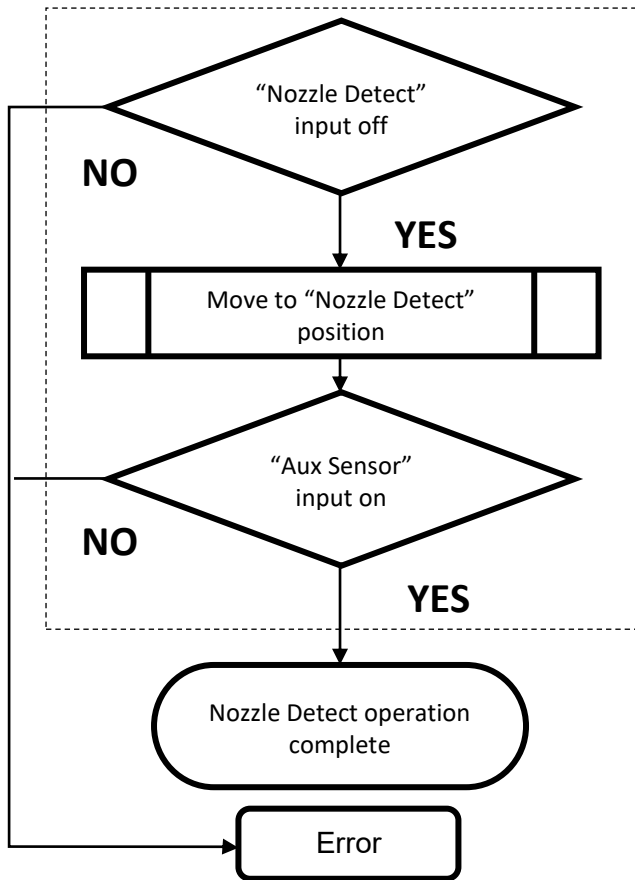

9. Nozzle Gas Flow Sensor (NGFS) Option

The INTELLIREAM® DD-IOL offers a nozzle gas flow sensor as a factory installed option (NAC40A) The integrated nozzle gas flow sensor measures gas flowing out the end of the torch nozzle. This method is advantageous to an inline flow sensor installed in the gas hose as there may be undetected leaks downstream. By measuring gas flow at the nozzle, the point of use, the system verifies adequate gas coverage for the weld puddle where it is required.

9.1. NGFS Specifications

GAS FLOW SPECIFICATIONS	
Max Pressure: 60 PSI	Flow: 10 - 60 SCFH
For use with CO2, AR, or Mixed gas (AR, CO2, He)	

9.2. NGFS Setup

Setup Procedure

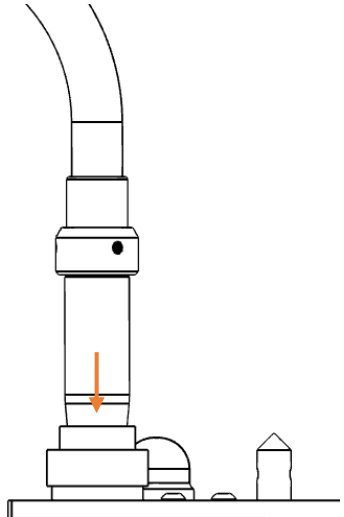
	<ol style="list-style-type: none">1. Using an independent measurement device, set the desired welding nozzle gas flow to the desired flow rate.2. Move the robot to bring the nozzle to the target position with the nozzle fully engaged in the flow cone. The module has a small amount of movement built into the spring mounts which will allow the nozzle to fully contact the cone for optimal flow transfer.3. Turn on gas flow through the nozzle at desired flow rate.4. Read the gas flow as a percentage of the sensor range (0-100) at address [1] (see section 3.4)5. Turn off gas flow.6. Move the robot to bring the nozzle out of the flow cone to the approach position.
--	--

9.3. NGFS Robot Position and Sequence Flow Chart

To properly detect gas flow, the correct robot position must be programmed with the nozzle inserted into the cone of the sensor. An approach position is recommended as the first step followed by the target position inside the cone.

The following figures and flowchart show the recommended programming sequence with nozzle location for the approach and target positions.

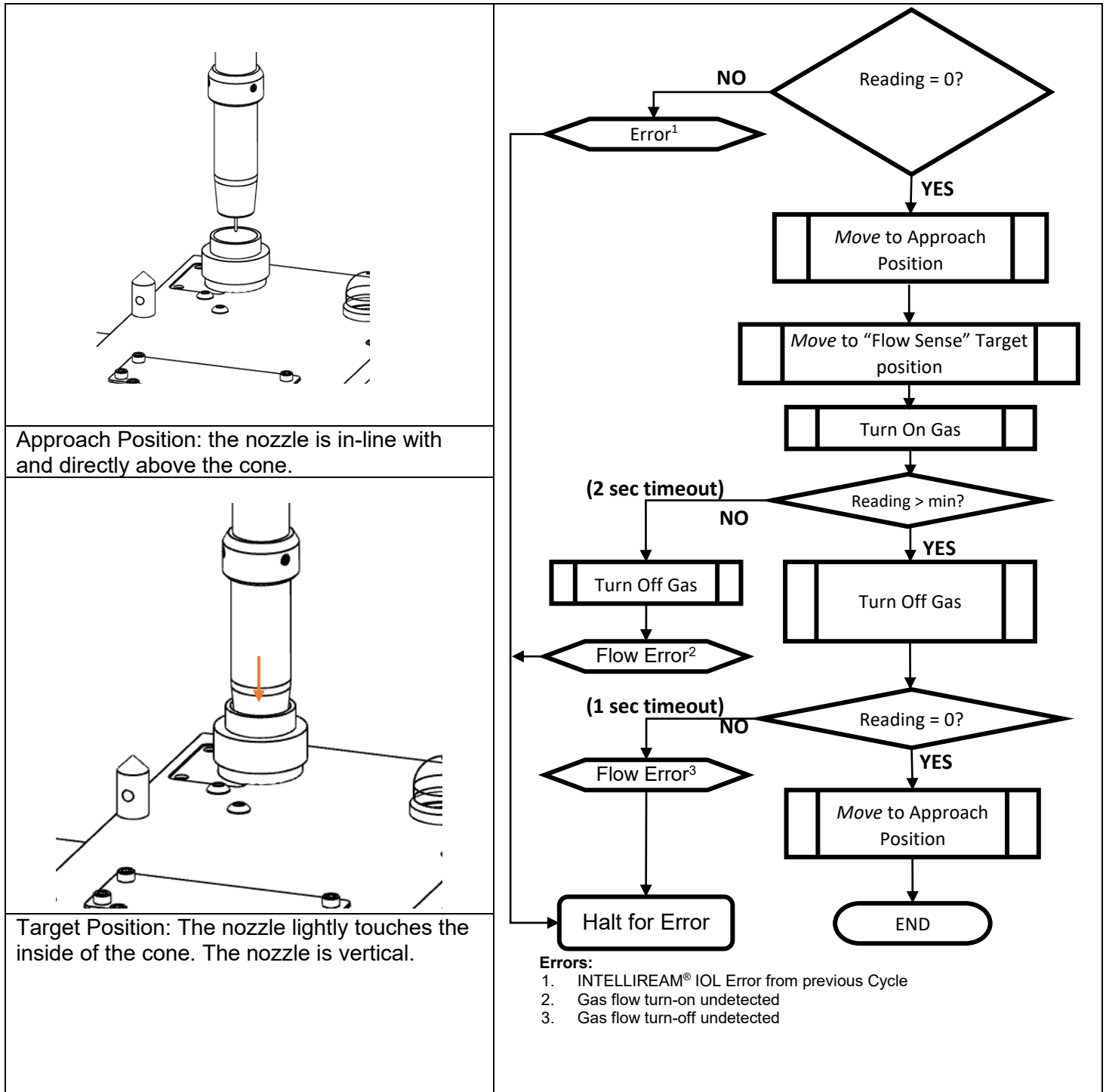

10. Settings

Several features may be set up to optimize performance of the INTELLIREAM® DD-IOL. To access the configuration menus, press and hold the settings button for the required time as shown below. The device status LEDs will change their color pattern to indicate the menu that is accessible at a specific time. Release the settings button when the color pattern for the desired configuration menu is shown.

	>3 sec (Mode)	>5 sec (Motor Test)	>7 sec
CLAMP	(Y)	(R)	(Y)
LIFT	(Y)	(R)	(Y)

Note: The default setting for each configuration is first and last in each sequence.

10.1. Running Mode

Several running modes are available to select from.

Automatic: Every aspect of the cycle is commanded, monitored, and checked by the control module.

Dry Run: The motor and fluid solenoid are disabled.

Timed: Bypass the "extended" sensor on the lift cylinder. The robot must hold the ream signal on for the reaming time. Auto Retry is disabled in this and the following modes:

Open: Bypass the "extended" and "retracted" sensor. The robot must hold the ream signal on for the reaming time and hold the robot in the clamp until the reaming bit is fully retracted.

Blind: Bypass all sensors. The robot must hold the ream signal on for the ream time and hold the torch in the jaws until the reaming bit is fully retracted and the clamp is fully opened.

INTELLIREAM® DD-IOL

Mode configuration: A specific running mode can be configured by the following procedure. Follow the steps outlined above to access the mode configuration menu. Upon releasing the settings button, the LEDs will flash green on top and bottom. This is the first in the sequence of teachable configurations.

Subsequent pressing and releasing of the settings button will sequence the following configurations in order of appearance. To register the desired configuration, press the reset button when that configuration is displayed.

Mode

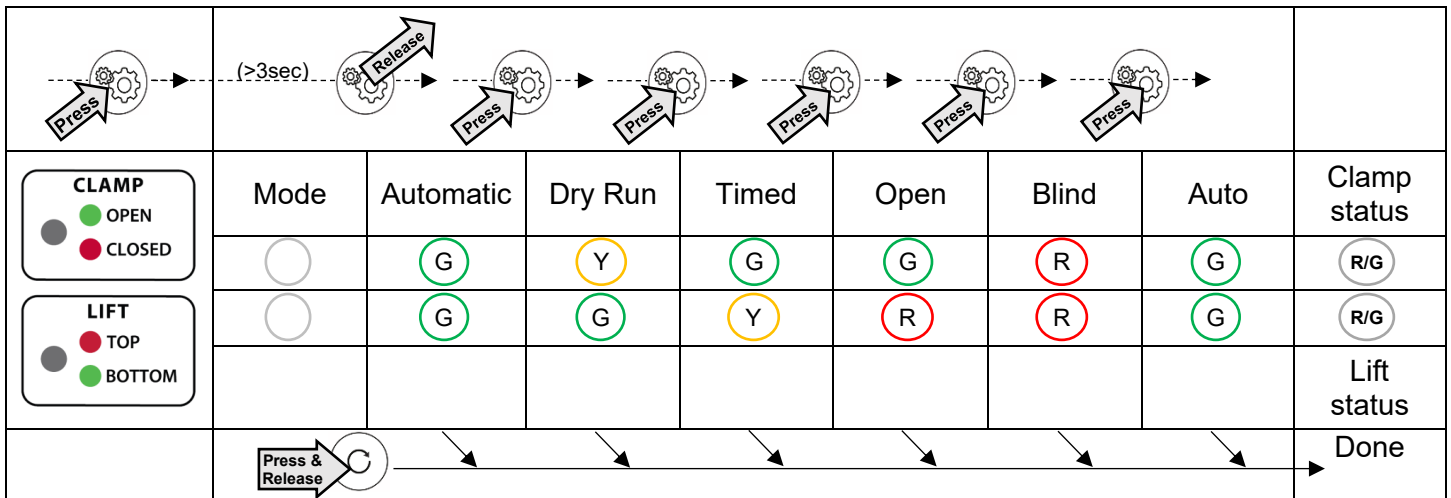

10.2. Motor Test

This feature allows a service technician to test the air motor function manually.

Follow the steps outlined below to access the motor diagnostic configuration menu. Upon releasing the settings button, the LEDs will flash red on top and bottom. This is the first in the sequence of teachable configurations. Subsequent pressing and releasing of the settings button will sequence the following configurations in order of appearance. To register the desired configuration, press the reset button when that configuration is displayed.

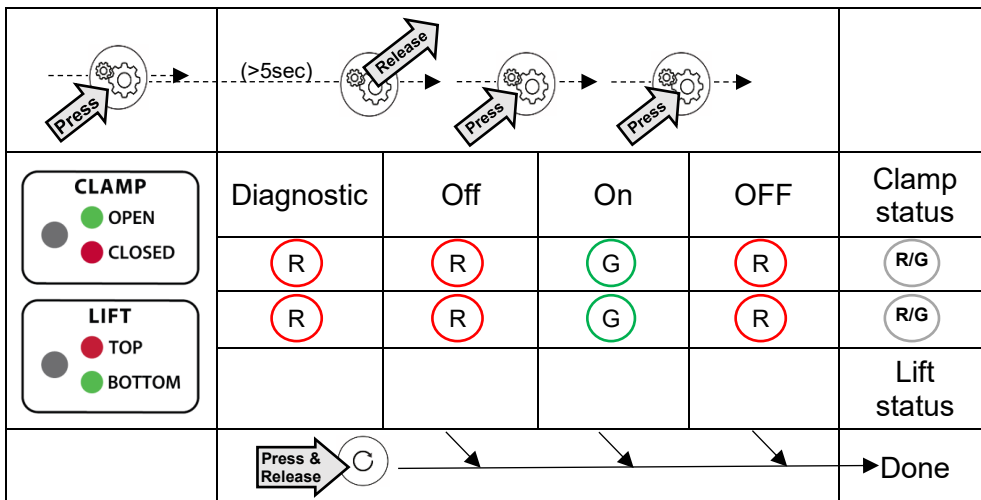

INTELLIREAM® DD-IOL

Motor Diagnostic Configurations:

Off: This feature is disabled.

On: This feature is enabled.

Note: Running the motor diagnostic will disable the feature so that it can only be run once each time it is enabled.

Motor Diagnostic Operation: Once the reset button is released, the unit will display the power-up sequence. Follow this procedure to test the air motor manually:

1. LIFT function: Press and hold the “LIFT” button to raise the reaming bit (without spinning) until it reaches the top position. Check that the “LIFT” LED on the control module is green.

WARNING: the lift will operate under this condition. KEEP HANDS CLEAR of the operating space of the reaming bit. This device is intended for one-man operation during test.



Once the INTELLIREAM® DD-IOL is at the top position (“LIFT” LED is green), release the “LIFT” button and the reaming bit will maintain its position.

2. CLAMP function: Press the “CLAMP” button to close and open the clamp. Check that the “CLAMP” LED on the control module changes from green to red when the clamp is closed.

WARNING: the clamp will operate under this condition. KEEP HANDS CLEAR of the operating space of the clamp and wire cutter. This device is intended for one-man operation during test.



Note: The LEDs on the control module will flash red from this point on in the sequence to indicate **CAUTION** for the operating devices being tested.

3. MOTOR function: With the reaming bit raised, press both the “CLAMP” button and “LIFT” button to test the “Motor” solenoid.



WARNING: the motor will operate under this condition. KEEP HANDS CLEAR of the operating area of the reaming bit. Do not operate with exposed long hair, jewelry, or loose clothing. This device is intended for one-man operation during test.

11. Preventive Maintenance

The INTELLIREAM® DD-IOL will require periodic maintenance to ensure a dependable service life. The following schedule is recommended.

Shut off the air supply and disconnect the power cable before making adjustments.

DAILY

- Check the fluid level in spray reservoir.
- Check the reaming bit visually.

WEEKLY

- Dump the spatter accumulated in the drawer of the mounting box or customer supplied catchment below the reamer.
- Check airlines for leaks and robot control cable for splits or cracks.
- Clean clamp gripping surfaces to ensure optimal nozzle gripping.

SPRAY CONTAINMENT UNIT (weekly)

- Remove and clean out spray cone and drain.
- Check collection jug.

NGFS (weekly)

- Clean the inside face of the flow cone to remove surface buildup.
- Clean debris from the main cavity by removing the plug at the bottom.
- Check the mesh filter of debris. Clean or replace as required.

12. Troubleshooting

Problem	Possible Cause	Solution
No device status LEDs on	<ul style="list-style-type: none"> -Power is off -Fuse is blown (controller cabinet) -Reset button defective -Circuit board defective 	<ul style="list-style-type: none"> -Turn power on -Replace fuse -Replace reset button -Replace circuit board
Clamp/Motor/Lift/Cutter not working	<ul style="list-style-type: none"> -Insufficient air supply -Air line cut, disconnected, or twisted -Motion enable is not active -INTELLIREAM® DD-IOL in setup mode -Excessive spatter buildup -Dry run mode selected -Defective solenoid -Check error codes 	<ul style="list-style-type: none"> -Set to 80 PSI, 15 SCFM -Replace or re-connect airline -Check IO-Link Pin 2 input. -Reset INTELLIREAM® DD-IOL -Ream more often -Select automatic mode -Replace necessary valves -Check cable wiring -Perform a visual inspection of the equipment
Ream bit does not retract	<ul style="list-style-type: none"> -Ream bit jammed in nozzle -Extended sensor defective -“Ream” output held on -Lift cylinder defective -Check error codes 	<ul style="list-style-type: none"> -Replace damaged parts -Replace extended sensor -Pulse “Ream” output for 0.5 sec -Replace lift cylinder
Controller cannot start a cycle or controller cannot complete a cycle	<ul style="list-style-type: none"> - “Ready” input signal not responding 	<ul style="list-style-type: none"> -Check error codes -Reset INTELLIREAM® DD-IOL
No anti-spatter liquid and/or no air flow from sprayer	<ul style="list-style-type: none"> -Low anti-spatter volume -Reservoir not vented -Fluid line blocked -Insufficient air supply -Solenoid valve defective -Spray nozzle clogged 	<ul style="list-style-type: none"> -Refill anti-spatter reservoir -Open vent if closed -Clean or repair fluid line -Set to 80 PSI -Replace solenoid valve -Clean or replace spray nozzle *HAND TIGHTEN ONLY
Wire cutter won't cut wire, but the cutter closes	<ul style="list-style-type: none"> -Insufficient air supply -Cutters are worn or damaged -Wire diameter too large 	<ul style="list-style-type: none"> -Set to 80 PSI -Replace damaged components -Check wire diameter

INTELLIREAM® DD-IOL

12.1. Error Codes

The INTELLIREAM® IOL reports errors using the status light. When an error is reported, the status light flashes the code at a rate of 2 flashes per second.

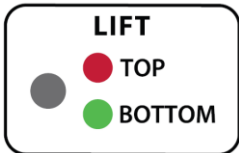
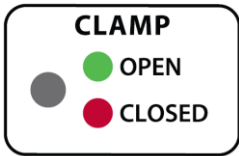

<p>When an error occurs during the reaming process, the clamp opens, the lift retracts, and the diagnostic report is shown with the top sensor LED in red. The LED will flash a certain number of times, pause, then repeat. The error count begins at 2.</p> <p>Count the number of flashes between the pause and use the following chart to find the cause of the problem.</p>
<p>2: Closing Fault: The clamp took too long to close.</p> <ul style="list-style-type: none"> -Check air inlet pressure -Check clamp sensor -Check clamp air lines -Check clamp solenoid -Check clamp cylinder
<p>3: Raising Fault: The lift cylinder took too long to extend from the retracted sensor.</p> <ul style="list-style-type: none"> -Check air inlet pressure -Check extending needle valve (top needle valve on lift cylinder) -Check retracted sensor (bottom) -Check lift air lines -Check lift solenoid -Check lift cylinder
<p>4: Extending Fault: The lift took too long to fully extend.</p> <ul style="list-style-type: none"> -Automatic retry; excessive spatter build up in the nozzle (ream more often), or incorrect programmed position of the nozzle not allowing the reaming bit to extend to full depth -Check air inlet pressure -Check extending needle valve (top needle valve on lift cylinder) -Check extended sensor (top) -Check lift air lines -Check lift solenoid -Check lift cylinder
<p>5: Lowering Fault: The lift cylinder took too long to retract from the top while lowering.</p> <ul style="list-style-type: none"> -Check air inlet pressure -Check retracting needle valve (bottom needle valve on lift cylinder) -Check extended sensor (top) -Check lift airlines -Check lift solenoid -Check lift cylinder
<p>6: Retracting Fault: The lift cylinder took too long to fully retract.</p> <ul style="list-style-type: none"> -Check air inlet pressure -Check retracting needle valve (bottom needle valve on lift cylinder) -Check retracted sensor (bottom) -Check lift airlines -Check lift solenoid -Check lift cylinder
<p>7: Opening Fault: The clamp took too long to open.</p> <ul style="list-style-type: none"> -Check air inlet pressure -Check clamp sensor -Check clamp airlines -Check clamp solenoid -Check clamp cylinder
<p>8: Short Circuit Fault: The output is short circuited.</p> <ul style="list-style-type: none"> -Check wiring to robot or PLC controller
<p>9: Solenoid Voltage Fault: The voltage to actuate the solenoids is too low.</p> <ul style="list-style-type: none"> -Check the voltage between the solenoid voltage and 0V and adjust power supply as needed. -Check the wiring of the solenoid voltage/emergency stop circuit or, motion enable input deactivated during automatic operation.

13. Pneumatic Components

The figure below shows the location for each pneumatic component.

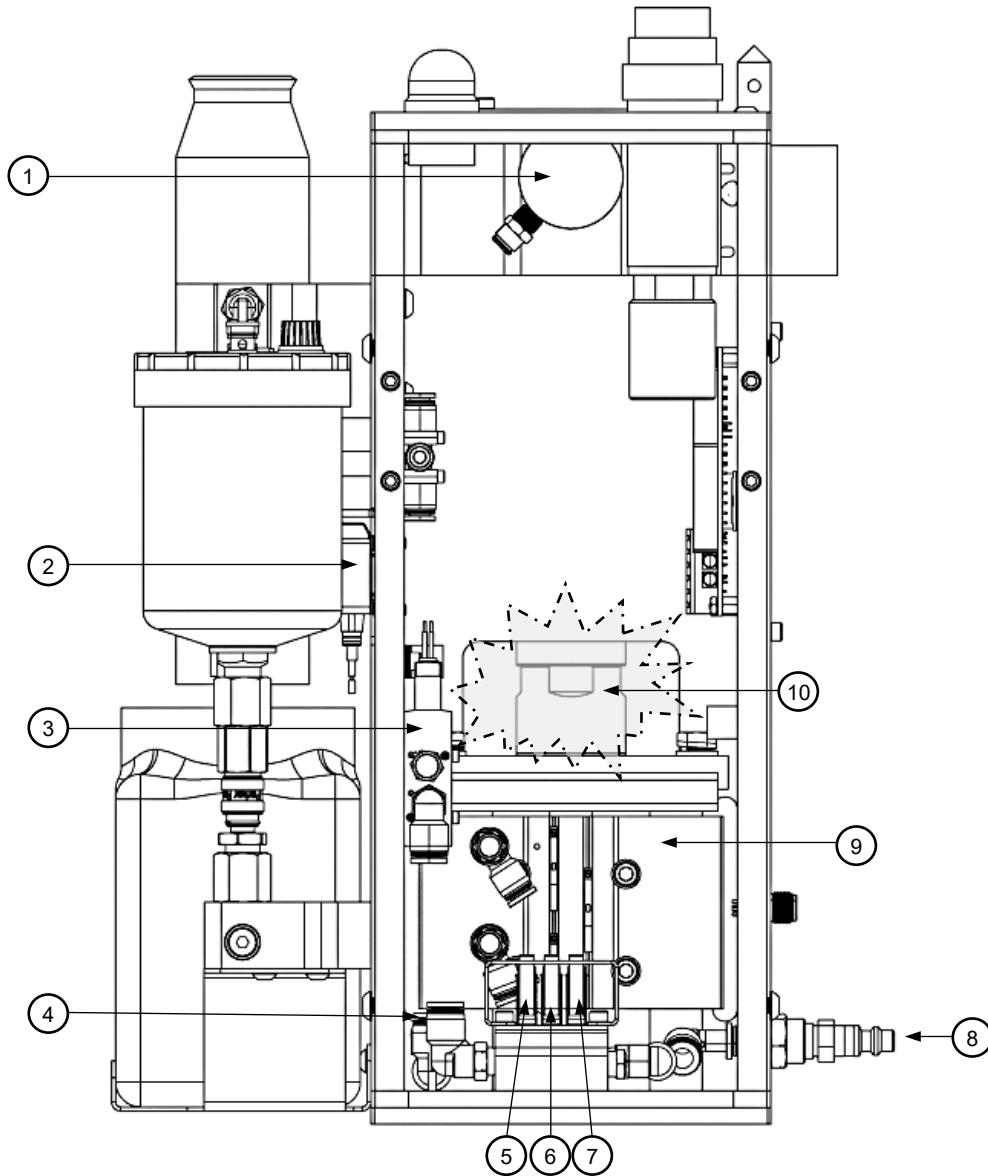

1	CLAMP CYLINDER
2	FLUID SOLENOID
3	MOTOR SOLENOID
4	MANIFOLD ASSEMBLY
5	SPRAY SOLENOID
6	CLAMP SOLENOID
7	LIFT SOLENOID
8	PNEUMATIC INLET
9	LIFT CYLINDER
10	AIR MOTOR (other side)

14. Electrical Diagram

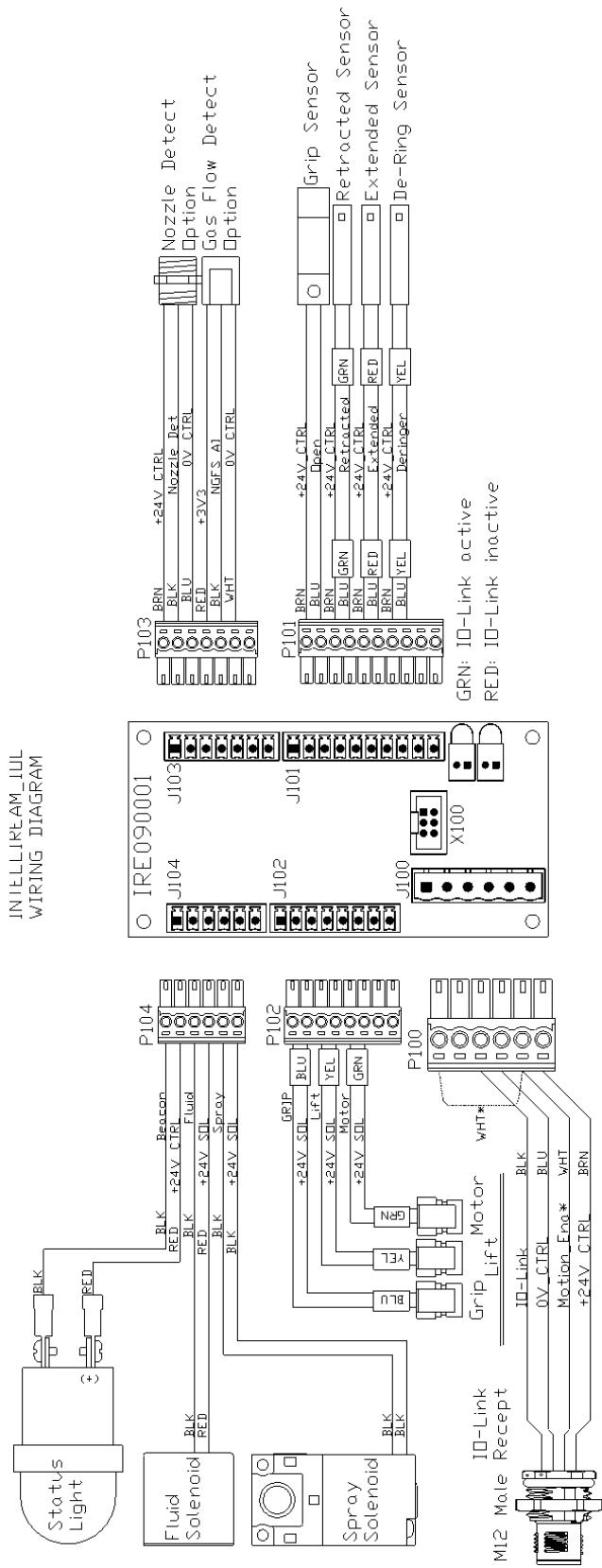

*Motion Enable:
 If motion enable is used - remove jumper and connect the white wire from the receptacle to pin 5 of P100.
 If motion enable is not used - remove white wire of receptacle from pin 5 and insert jumper from pin 1 to pin 5 of P100.

15. Replacement Parts List

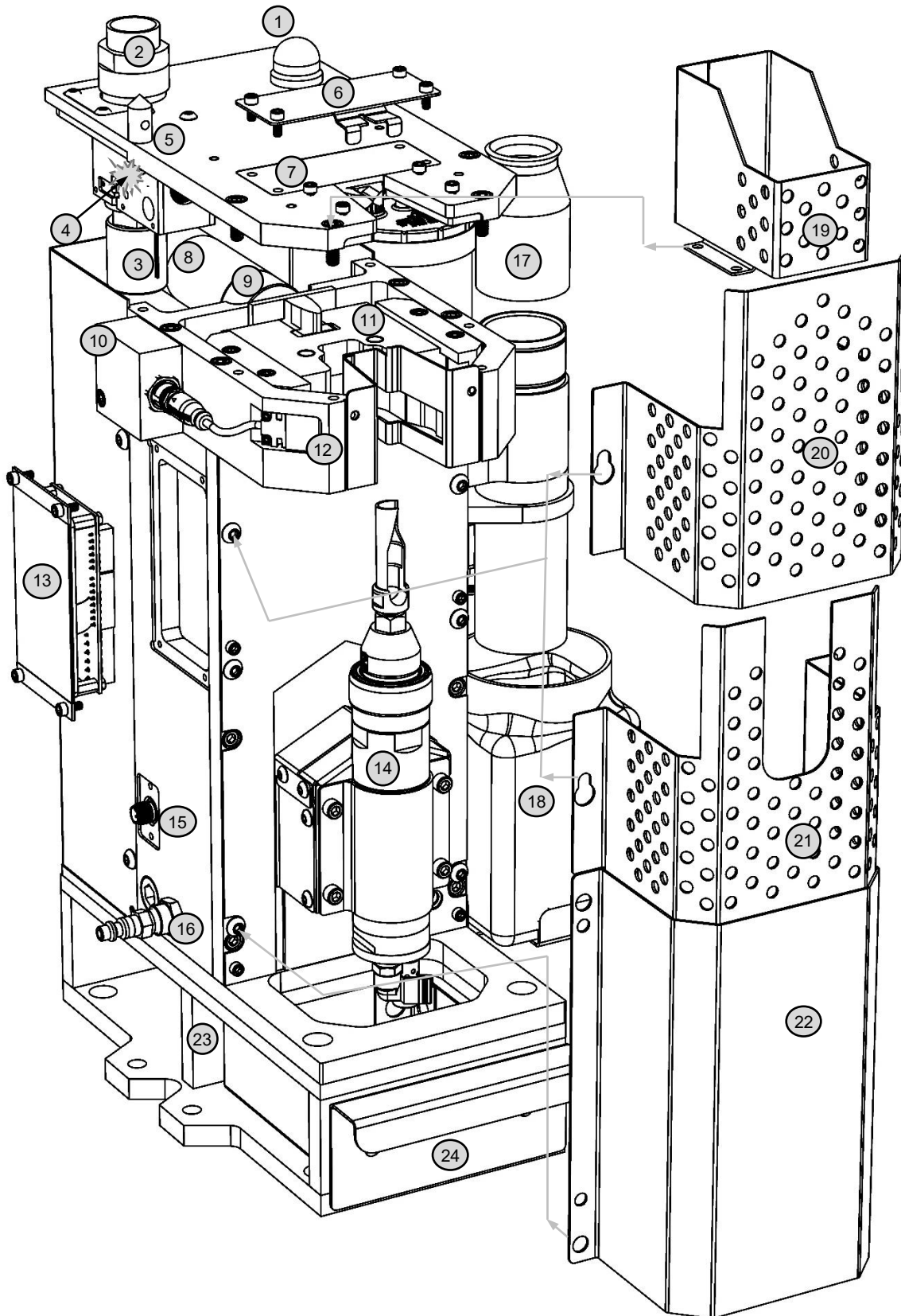

INTELLIREAM® DD-IOL

ITEM	PART #	DESCRIPTION
1	IRE020099-09	STATUS LIGHT ASSEMBLY
2	NAC40A	NGFS SINGLE
3	NAC40-5	SENSOR DRAIN PLUG
4	NAC40-2R	NGFS SENSOR ASSEMBLY
5	IRW010008-00	TCP CHECK PIN
6	IRW010007-03	WIRE CUTTER GUARD (option)
7	IRW010099-00	WIRE CUTTER ASSEMBLY (option)
8	IRE020099-04	OPEN SENSOR ASSEMBLY
9	IRP120099-00	CLAMP CYLINDER ASSEMBLY DD
10	IRF120003-00	BACK COVER DD
11	IRG010099-00	CLAMP ASSEMBLY
12	IRE020099-13	NOZZLE DETECT SENSOR REPLACEMENT
13	IRE070099-07	RCM-IOL MODULE COMPLETE
	•IRE070008-00	RCM-IOL MEMBRANE
	•IRE090001-00	PC BOARD IOL W/ MICROCONTROLLER
14	NTP32R	REAM MOTOR ASSEMBLY
15	IRE020021-00	M12 RECEPTACLE MALE
16	IRP010006-02	PNEUMATIC FITTING 1/4in
17	IRS120099-10	SPRAY CONE ASSEMBLY O-RING [SECTION 5.3.1]
	NAC30-3	SPRAY CONE (PLUNGER BASE) [SECTION 5.3.2] (option)
18	NST-5	32OZ PLASTIC CONTAINER
19	IRG120002-00	TOP GUARD DD (option)
20	IRF120008-00	REAMING BIT GUARD FULL DD
21	IRF120010-00	REAMING BIT GUARD OPEN DD (option)
22	IRF120099-00	FRONT COVER DD
23	IRX120099-00	MOUNTING BOX DD WITH TRAY (option)
24	•IRX120099-01	BOX TRAY DD

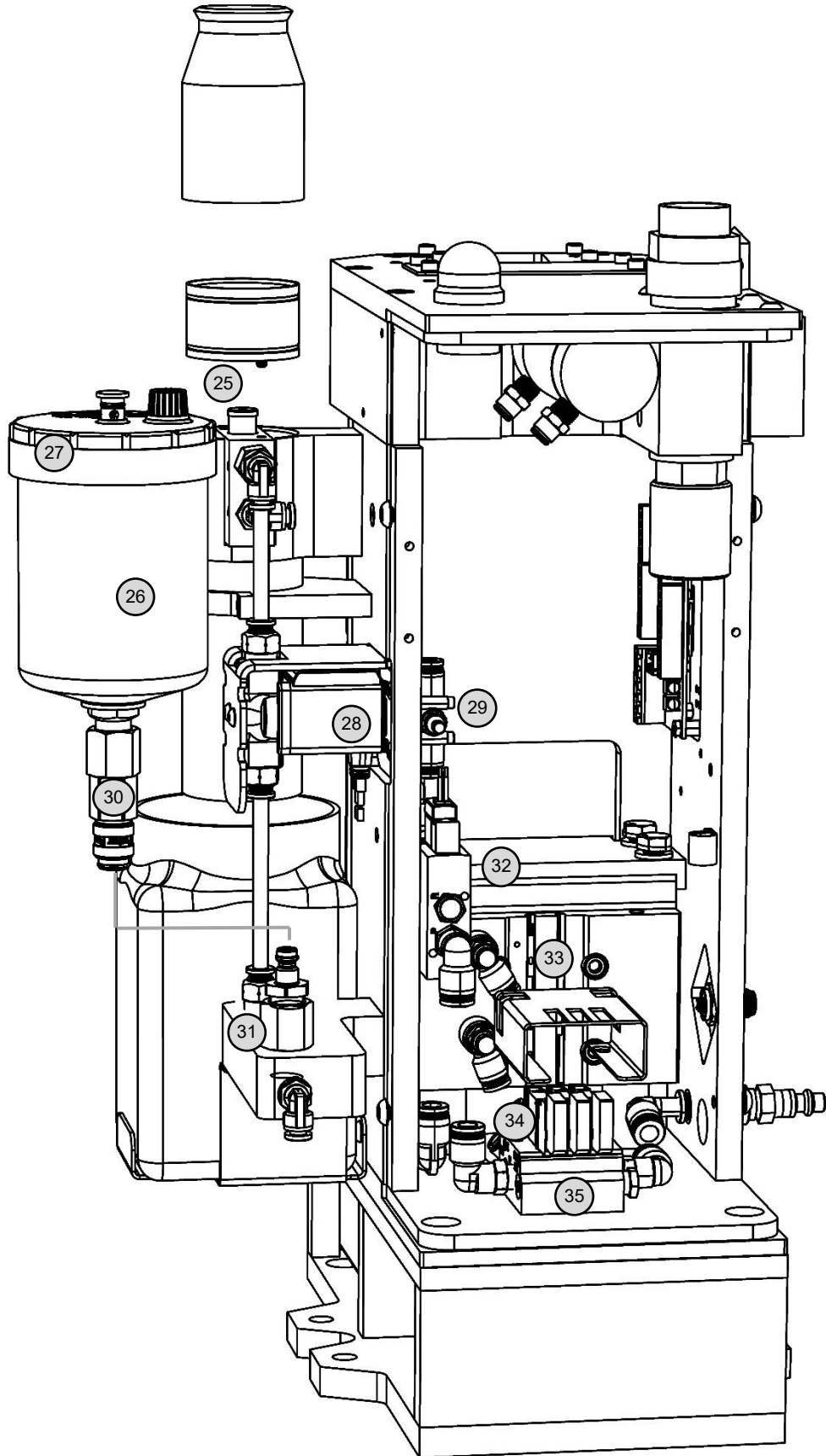

ITEM	PART #	DESCRIPTION
25	NAC30-2R	SPRAY NOZZLE REPLACEMENT ASSEMBLY
26	IRS120099-03	FLUID RESERVOIR ASSEMBLY DD
27	IRS010005-01	FLUID RESERVOIR LID
28	IRP120099-01	FLUID SOLENOID ASSEMBLY DD
29	IRP120099-04	SPRAY FLOW CONTROL ASSEMBLY
30	IRS120099-05	FLUID FEMALE QUICK CONNECT ASSEMBLY
31	IRS120005-00	FLUID MALE QUICK CONNECT
32	IRP120099-03	MOTOR SOLENOID ASSEMBLY DD
33	IRE010012-00	LIFT SENSOR
34	IRP120002-00	5-WAY SOLENOID (cylinders, spray)
35	IRP120099-02	MANIFOLD ASSEMBLY DD

Accessories

PART #	DESCRIPTION
IRB010500-00	REAMING BIT, 1/2" (W/WASHER)
IRB010501-00	REAMING BIT, BOTTLENECK, 1/2" (W/WASHER)
IRB01M155-00	REAMING BIT, 15.5mm (W/WASHER)
IRB020625-00	REAMING BIT, 5/8" (W/WASHER)
IRB010750-00	REAMING BIT, 3/4" (W/WASHER)
IRE010090-20	ROBOT CABLE, 90 Degree 20FT
IRE010090-30	ROBOT CABLE, 90 Degree 30FT
IRX120099-30	FLOOR MOUNT STAND, 30" DD with Tray
•IRX120009-00	STAND TRAY DD
IRX120099-02	WING BOX ASSEMBLY DD

INTELLIREAM® DD-IOL

Warranty

NASARC Cert-Equip WARRANTY POLICY

INTELLIREAM® DD-IOL is warranted by **NASARC** to the original commercial or institutional end user/owner against defects in materials and workmanship as follows:

Motor, Solenoids, circuit board, cylinders – 1 year

External parts, INTELLIREAM® DD-IOL, spray nozzle, cables, and accessories – 90 days

The warranty becomes effective on the date of purchase. During the warranty period, equipment covered by the warranty and found to be defective will be repaired or replaced at the manufacturer's discretion without charge. The manufacturer's responsibility is limited to repair or replacement of damaged or defective parts. The equipment must be returned, transportation charges prepaid with proof of purchase date, to an authorized service center or to **NASARC**. If a product warranty card has not been completed or proof of purchase is not available, the warranty will be deemed to become effective at the time the product leaves the factory authorized **NASARC** warehouse. Warranty repair service does not extend the period of warranty beyond the original period. The warranty is not transferable.

This warranty does not cover defects in the equipment caused by ordinary wear and tear, abuse, misuse, accident, or any other cause that is not the result of defective materials or workmanship.

Repair or replacement is the exclusive remedy for defective equipment under this warranty. This warranty is in lieu of all other warranties written and implied, including any implied warranty of fitness for a particular purpose of this equipment. **NASARC** shall not be liable for any consequential or incidental damages for breach of any express or implied warranty of this equipment.

The month of manufacture can be found on the serial plate

```
+----- yy:  Year
| +----- mm:  Month (01 .. 12)
| | +---- nnn:  Unit number within the month (001..999)
| | |
IRyymmnnn
```

For example, IR2208033 is the 33rd unit manufactured in August (08) of 2022 (22)